

BIKE

ENGLISH

USER

MAN-

-UAL

READ
BEFORE
YOUR
FIRST
RIDE



GE

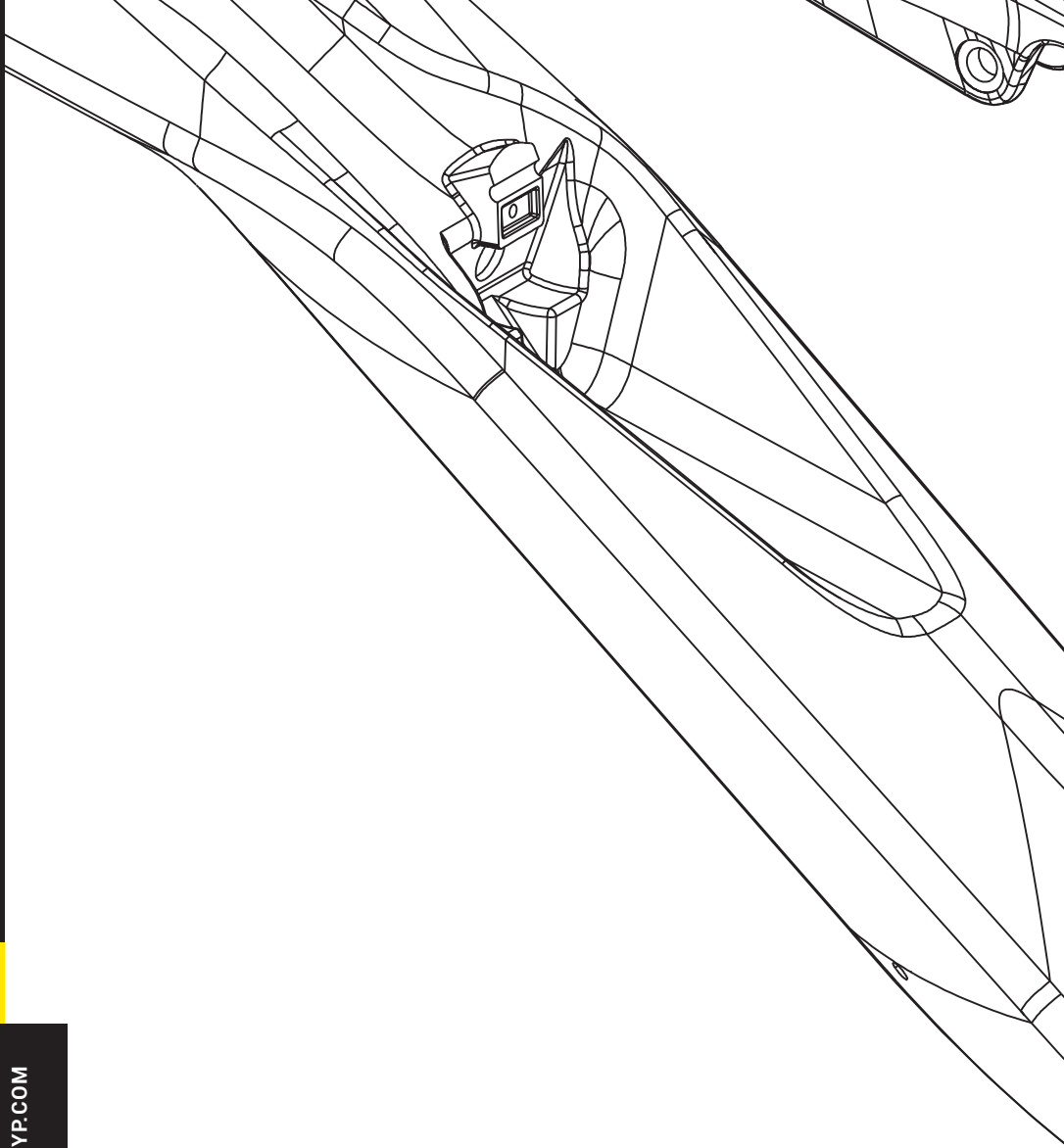

A detailed line drawing of a bicycle frame, showing the top tube, down tube, seat tube, and chain stays. The drawing is oriented vertically, with the top of the frame at the top of the page. The frame is shown in a perspective view, highlighting its curved and angular structure. The drawing is composed of clean, black lines on a white background.

GE
BIKE USER MANUAL

ENGLISH

Contents

1	INTRODUCTION	5			
	Greyp Bikes Disclaimer	5			
	General warning	5			
	General information	6			
	Safety information	7			
	General information about assembly	8			
2	GENERAL NOTES ABOUT RIDING	9			
	Riding tips	9			
	Pre-ride inspection	10			
	Riding tips for children	10			
	Seat post – basics	11			
	Brakes – basics	11			
	Suspension – basics	12			
	Rear suspension	12			
	Adjusting rebound	13			
	Adjusting threshold	13			
	Adjusting lockout	14			
				Front suspension	14
				Shock pressure chart	14
				Recommended tire pressure	15
				Assembling parts supplied unassembled	16
			3	BATTERY AND CHARGER	19
				Battery technical data	19
				Important battery information	20
				Charging process	22
				Battery life	24
			4	SYSTEM FUNCTIONS	25
				Bike parts	25
				Control unit functions	26
				Display unit information	27
				Power on	28
				Stand by mode on	28
				Stand by mode off	28

Power off	29	Shock	39
Walk assist mode	29	Lubrication	40
Lights on/off	29	7 WARRANTY	41
Joystick	30	General	41
Assist level up/down	30	Battery	42
Info and Pair a bike screen	31	Frame	43
Manual software update	31	Motor	43
Battery pack mount/dismount	32	Electronics	43
5 BIKE MAINTENANCE & RANGE	33	Brakes	43
Maintenance	33	Suspension	43
Range	35	Drivetrain	44
Shifting recommendations	36	How to file a claim	44
Recommended tightening of fasteners	36	8 DISPOSAL	45
6 CLEANING THE BIKE	39	Only for EC countries:	45
Chain	39	9 EC – DECLARATION OF CONFORMITY	47
Fork	39		

1

Introduction

This user instruction manual is developed for your Greyp G6 only. It contains important safety, performance and technical information, which you should read before your first ride and keep for reference. You should also read the entire User Manual, because it contains additional important general information and instructions that you should follow.

If you do not have a copy of the User Manual, please download it for free at www.greyp.com or obtain it from your nearest Authorised Greyp Retailer. In case of discrepancy, the english version shall prevail.

Greyp Bikes Disclaimer

Any modifications of the bike are strictly forbidden and Greyp Bikes d.o.o. will bear no liability whatsoever for the consequences of such modifications. Greyp Bikes d.o.o. does not grant, explicitly or implicitly, to any party any patent rights, licenses or any other IP rights, whether with regard to such information itself or to anything described by such information. The information provided by Greyp Bikes d.o.o. hereunder is provided as is, where is and with all faults, and the entire risk associated with such information is entirely with the buyer. The information provided in this document is proprietary to Greyp Bikes d.o.o., and Greyp Bikes d.o.o. reserves the right to make any changes to the information in this document or to any products and services at any time without notice.

You should check www.greyp.com for any changes made in the User Manual.



Greyp Bikes d.o.o.,
Ljubljanska 7, 10431 Sveta Nedelja, Croatia,
15th of February 2020.

General warning

This manual contains many "WARNINGS" and "CAUTIONS" concerning the consequences of failure to maintain or inspect your bike and of failure to follow safe cycling practices.

The combination of the safety alert symbol and the word WARNING indicates a potentially hazardous situation which, if not avoided, could result in serious injury or death.

The combination of the safety alert symbol and the word CAUTION indicates a potentially hazardous situation which, if not avoided, may result in minor or moderate injury, or is an alert against unsafe practices.

Many of the WARNINGS and CAUTIONS say *you may lose control and fall*. Because any fall can result in serious injury or even death, we do not always repeat the warning of possible injury or death.

As it is impossible to anticipate every situation or condition which can occur while riding, this User Manual makes no representation about the safe use of the bicycle under all conditions. There are risks associated with the use of any bicycle which cannot be predicted or avoided, and which are the sole responsibility of the rider.

General information



Important notice: Please make sure you read this User Manual before operating a Greyp bike for the first time. It is very important to follow the instructions in the manual to make sure you use Greyp in the proper way. Greyp Bikes d.o.o. reserves the right to change the design, components and specifications at any time without notice and without any obligation. The illustrations and pictures in this manual are for demonstration purposes only.

- » **EU** - *The G6.1 and G6.2 are high-performance bicycles. The G6.3 and G6.20 are off-road vehicle and they should not be ridden on public roads..*
- » **US** - *The G6.1(US) and G6.2(US) are CLASS 1 electric bicycle. The G6.3(US) and G6.20(US) are CLASS 3 electric bicycles.*

G6 bikes are intended to be used on gravel, paved and non-paved hiking trails (with several roots, thresholds, rocks and small drops) and rougher unpaved terrain, with jumps and drops not more than 1m (maximum height).



WARNING — Please contact your dealer or manufacturer before trying to repair your Greyp bike. This User Manual is not intended as a service and repair manual.

The Greyp G6 is classified as a pedelec. The G6 is a vehicle where the rider's pedalling is assisted by an electric motor with 5 assist and torque levels, which gives you a range of power assistance.

Motor support will automatically switch off when you reach a maximum speed of: 25km/h for G6.1 and G6.2; 32km/h (20mph) for G6.1(US) and G6.2(US); 45km/h (28mph) for G6.3, G6.20, G6.20(US) and G6.3 (US). A driver's license or insurance is typically not required. Regardless of its classification, it will only provide motor support only while pedalling.

Before using your Greyp bike, please inform yourself of all applicable legal requirements and regulations in your country or state. There may be restrictions on riding your Greyp bike on public roads, cycling paths, and/or trails. There may also be applicable helmet requirements, age restrictions or license or insurance requirements. As laws and regulations regarding electric vehicles vary by country and/or state and are constantly changing, please make sure you obtain the latest information. You should also regularly see your authorized Greyp retailer for updated information.

All Greyp G6 bikes have a fixed pre-set speed limit at which the motor support will automatically shut off. Tempering is to interfere with bike in order to cause damage or make unauthorized

alterations (i.e. excluding the exchange of sprocket with non-original parts) Any (attempted) tampering with the power output and/or system (i.e. excluding the exchange of sprocket with non-original parts) is prohibited, will void the warranty, is extremely dangerous and could result in severe and/or fatal injuries. In case of tampering we recommend that you stop using bike and call authorized Greyp retailer.

Safety information

Please, carefully read all the warnings and notes in this User Manual before using your Greyp bike.



WARNING – You add to your risk of injury when you use your bicycle in an incorrect manner. Misuse can add stress to your bike. High stress can cause the frame or a part to break and increase your risk of injury. To decrease your risk of injury, use your bicycle in the manner for which it was designed.



WARNING – As with all mechanical components, the EPAC (Electrically Power Assisted Cycles) is subjected to wear and high stress. Different materials and components may react to wear or stress fatigue in different ways. If the design life of a component has been exceeded, it may suddenly fail, possibly causing injuries to the rider. Any form of crack, scratches or change of colouring in highly stressed areas indicate that the lifespan of the component has been exceeded and it should be replaced.



WARNING – For composite components, impact damage may be invisible to you and may result in serious personal injury or death. If composite components exhibit any signs of damage, do not use them and immediately bring them to your authorized Greyp retailer for inspection.

The A-weighted emission sound pressure level at the driver's ears is less than 70 dB(A)



WARNING – Inappropriate handling of a Greyp bike can cause damage, injury and/or death. Please make sure you learn how to operate your Greyp bike in a safe and responsible way.

The Greyp G6 is intended to transport only one person at a time. If you allow somebody else to use your Greyp bike, please provide them with this User Manual.

We advise keeping the original box that the bike came with for the warranty period in case there are any troubles.



WARNING – We strongly advise you to wear a helmet and other safety equipment while riding your bike. In some countries, there is an obligation to wear a helmet. Please check if this is the case in your country.

Only ride at ambient temperatures between 5°C (41°F) and 40°C (104°F).



WARNING – Greyp lights are primarily designed as auxiliary lights and you should take care that you use lights that are in accordance with the provision in force in the country of use.



WARNING – Reflectors, which function only when light shines on them, are not a substitute for lights. Riding in dark conditions or at times of poor visibility without adequate lighting is extremely hazardous.



General information about assembly

This User Manual is not intended as a comprehensive use, service, repair or maintenance guide. Please see your authorized Greyp Bikes partner for all service, repairs or maintenance.

WARNING — Do not alter or modify any parts of your Greyp bike. Do not install incompatible components or hardware.

The maximum permissible total weight (vehicle + driver + luggage) of Greyp G6 is 150kg [330.7 lb].

VEHICLE	THE PERMISSIBLE TOTAL PAYLOAD (DRIVER + LUGGAGE)	VEHICLE WEIGHT
G6.1 AND G6.1(US)	125.5 kg [276.7 lb]	24.5 kg [54 lb]
G6.2 , G6.20, G6.20(US) AND G6.2(US)	125 kg [275.6 lb]	25 kg [55.1 lb]
G6.3 AND G6.3(US)	126 kg [277.8 lb]	24 kg [52.9 lb]

Please find additional safety, performance and service information for specific components such as suspension, brakes or motor in the Manufacture's Guidelines.

ONLY FOR BIKES SOLD IN THE USA

This device complies with part 15 of the FCC Rules. Operation is subject to the following two conditions: (1) This device may not cause harmful interference, and (2) this device must accept any interference received, including interference that may cause undesired operation.

Contains FCC IDs: QIPPLS8-USR4, Z64-WL18SBMOD

NOTE — This equipment has been tested and found to comply with the limits for a Class B digital device, pursuant to part 15 of the FCC Rules. These limits are designed to provide reasonable protection against harmful interference in a residential installation. This equipment generates, uses and can radiate radio frequency energy and, if not installed and used in accordance with the instructions, may cause harmful interference to radio communications. However, there is no guarantee that interference will not occur in a particular installation. If this equipment does cause harmful interference to radio or television reception, which can be determined by turning the equipment off and on, the user is encouraged to try to correct the interference by one or more of the following measures:

- » *Reorient or relocate the receiving antenna;*
- » *Increase the separation between the equipment and receiver;*
- » *Connect the equipment into an outlet on a circuit different from that to which the receiver is connected;*
- » *Consult the dealer or an experienced radio/TV technician for help.*



CAUTION- Changes or modifications not expressly approved by the party responsible for compliance could void the user's authority to operate the equipment.

2

General notes about riding

The G6 motor provides pedal assistance while you are pedalling, and the the bike is in motion. The amount of pedal assistance will be higher or lower depending on the amount of force applied to the pedals. If you stop pedalling, the motor will stop providing any assistance. The Greyp G6 can also be ridden as a normal bicycle without motor assistance by switching the vehicle to the OFF mode. The same applies if the battery is empty.

The Greyp G6 has a walk-assist mode (the motor engages without pedal force being applied) which is designed to provide assistance when walking the vehicle up a hill.

Riding tips

Below are some riding tips, which may also reduce component wear and increase battery range.

- » *Pay attention to your speed when going into a corner and be sure to stop pedaling well before entering the corner. Otherwise you may have too much speed as you enter the corner ;*
- » *Ride efficiently and look ahead. Any time a braking force is applied, more energy is needed to get the vehicle back up to speed ;*
- » *Shift gears regularly to stay in an optimal cadence range and downshift before coming to a stop ;*
- » *Reduce pedal force before initiating a gear shift to reduce drivetrain wear ;*
- » *Check the tire pressure regularly. Low pressure can cause the tires to roll inefficiently ;*
- » *If your vehicle is exposed to cooler weather, keep the battery stored indoors until just before riding ;*
- » *Do not expose your vehicle to excessive heat ;*
- » *Only carry the cargo you need. More cargo weight requires more energy to move.*



WARNING – Improper derailleur shifting technique could cause your chain to jam or come off, causing you to lose control and fall.

Pre-Ride Inspection

- » *Prior to the first ride, charge the battery to 100% ;*
- » *Check to ensure that the quick-release levers or axle nuts are tight ;*
- » *Check the brake pads for excessive or uneven wear ;*
- » *Make sure that all bolts on the brakes and steering parts are tight ;*
- » *Spin the rims – check for wobbles while sighting on the rims*
- » *Check the tire pressure ;*
- » *Check the tires for excessive wear, cracking or gashes ;*
- » *Check that the gears shift smoothly ;*
- » *Check the chain for rust, dirt, stiff links or noticeable signs of wear (the chain should be clean and lubricated, be sure to use a chain-elongation gauge) ;*
- » *Apply the front brake, and push the bike forward and backward (the headset should be tight and not make any clunking noises).*



WARNING – Being aware of your surroundings can drastically reduce incidents. If you are on the road be aware of traffic and road conditions. In off-road conditions there may be less friction between the tires and the ground and it can make you lose control and cause an accident.



CAUTION – Your field of view is particularly shorter, in fact very short, when riding at night. Obstructions are more difficult to see at night. Use extreme caution, slow down to compensate for the much shorter reaction time and ride at a speed appropriate to your field of vision and surroundings.

Riding tips for children

Greyp bikes are only designed and tested for use by one person at a time. Greyp bikes are not intended for children under 16 years. Do not allow children under 16 years old to drive a Greyp bike.

Seat post – basics



WARNING – Make sure that the seat position is adjustable so that the feet of a seated rider can touch the ground. If your bicycle does not fit properly, you may lose control and fall.



WARNING – After any saddle adjustment, be sure that the saddle adjusting mechanism is properly seated and tightened before riding. A loose saddle clamp or seat post clamp can cause damage to the seat post, or can cause you to lose control and fall. A correctly tightened saddle adjusting mechanism will allow no saddle movement in any direction. Periodically check to make sure that the saddle adjusting mechanism is properly tightened.

Greyp G6 bikes have a telescopic seat post. Familiarise yourself with the features of the seat post before your first ride. Only operate the telescopic seat if it will not distract any of your attention from the road and terrain. Refer to information from the telescopic seat post manufacturer (www.kssuspension.com). A telescopic seat post allows the saddle height to be adjusted by operating a lever underneath the saddle or a remote control on the handlebars, both at a standstill and while riding.

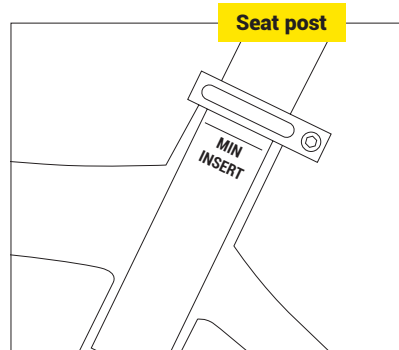

The saddle height is always measured with the crank arm pointed down and in line with the seat tube. The distance from the centre of the pedal axle to the top of your saddle is your saddle height. Before changing the height of your saddle, you should measure your current saddle height.

All seat post models must be inserted into the bike seat tube to cover the minimum insertion line indicated on the seat post. Insufficient insertion of the seat post into the bike's frame seat tube could result in damage to the seat post and/or vehicle and may result in a loss of control of the vehicle, which may lead to serious injury or death.

To lower the saddle, weight the saddle firmly with your hand or sit on the bike while pressing and holding the actuation lever or remote. Release the lever when the desired height is reached.

To raise the saddle, actuate your seat post by pulling the lever or handlebar remote. Unweight the saddle and release the lever when the desired height is reached.

You can raise and lower your saddle to any desired position within the seat post's travel.

Brakes – basics



WARNING – Braking devices on Greyp bikes are a high-performance product, offering a stopping power greater than normal brakes. As a result, less effort is required to lock up the wheel when braking. Be careful, as a locked wheel can result in loss of control over the vehicle and can cause injuries. Brakes are essential for the safe use of a vehicle - an improper setup and use of the brakes can make you lose control and cause an accident, with unpredictable consequences and/or potentially serious injuries. Disc brakes get VERY hot when used. Commonly the left lever operates the front brake and the right lever operates the rear brake (this may vary depending on country).



CAUTION – NEVER touch the calliper or the rotor immediately after use. Make sure the brakes have cooled down before working on them.

The brake rotors must be installed on wheels that are suitable for this type of brake system. A wheel with an insufficient spoke section or with radial spoke lacing can break under normal use of the braking system and cause serious injury, accident or death. Check with your wheel manufacturer BEFORE installation to ensure compatibility.

Check the spoke tension and condition frequently. A damaged spoke may break suddenly and interfere with the braking system. This may result in serious personal injury, accidents or death.



WARNING – Before every ride, make sure there are no fluid leaks in the system by applying the lever and holding it down as far as it will go. Check the hose connections and the brake fluid reservoir for any leaks. Consult a professional mechanic if there are fluid leaks. A fluid leak can cause a serious accident or death!



CAUTION – Braking distances may be greater in wet weather and use of the brakes can make you lose control, fall and cause an accident.

Test the brakes and your braking technique on flat and even ground before using the bike in more severe conditions.

You can find more info about Formula Cura brakes on www.rideformula.com

Suspension – basics



WARNING – Improperly installed, maintained or adjusted components are extremely dangerous and could result in severe and/or fatal injuries. If you have any questions about the installation of these components, consult a qualified bicycle mechanic.

Rear Suspension

Suspension sag can be used to set the proper suspension spring rate for the rider. Sag is the amount (percentage) the suspension compresses when the rider, including riding gear, is seated on the bike in the riding position. Setting the proper sag allows the wheels to maintain traction without using too much of the travel reserved for shock absorption. More sag increases small bump sensitivity, while less sag decreases small bump sensitivity. Set the spring sag before making any other tuning adjustments. G6.1 & G6.1(US) are using Rock Shox Monarch RT1 216x63 and G6.2, G6.20, G6.20(US), G6.2(US), G6.3 & G6.3(US) are using Rock Shox Monarch RT3 216x63.

Before setting sag, set the dampers to the full open positions. Rotate the adjusters counter-clockwise until they stop. Set the shock to the open position.

Beginning with the shock fully deflated, pressurize the air spring chamber to 100 psi. Remove the pump. Do not compress the suspension with the pump attached.

Fully compress the shock five times to equalize the positive and negative air springs.

Pressurize the shock (PSI) to the equivalent of the rider's total weight (lbs), including gear. Example: 160 lbs = 160 PSI (0.15 bar = 1 kg). Remove the pump. Compress the shock once more to equalize air pressure.

With your riding gear on, and an assistant holding the bike, step onto the vehicle and lightly cycle the shock two to three times.

While seated on the bicycle, have an assistant slide the sag o-ring against the wiper seal. Gently step off the vehicle without compressing the shock.

Note the sag percentage where the o-ring stopped. The correct sag percentage for Debon Air shocks is 30%. Sag can be set $\pm 5\%$ as preferred. If your target sag percentage is not achieved, air pressure must be adjusted. Increase air pressure to decrease sag. Decrease air pressure to increase sag.

Adjusting rebound

Monarch rebound damping controls suspension rebound speed after compression. Suspension rebound speed affects the wheel contact with the ground, which affects control and efficiency. The shock should rebound quickly enough to maintain wheel traction without feeling 'bouncy'. Too much rebound damping will not allow the shock to rebound quickly enough for the next bump. To increase the rebound speed, rotate counter-clockwise. To decrease the rebound speed, rotate clockwise.



Adjusting the threshold (only for models G6.2&G6.3)

The threshold, or *pedal* setting prevents the shock from compressing until moderate impact or downward force occurs. Use the *threshold* setting to increase pedalling efficiency on flat, rolling, and smoother terrain. To activate the *threshold* setting, rotate the lever, or actuate the remote until it reaches the threshold position indicated on the shock.

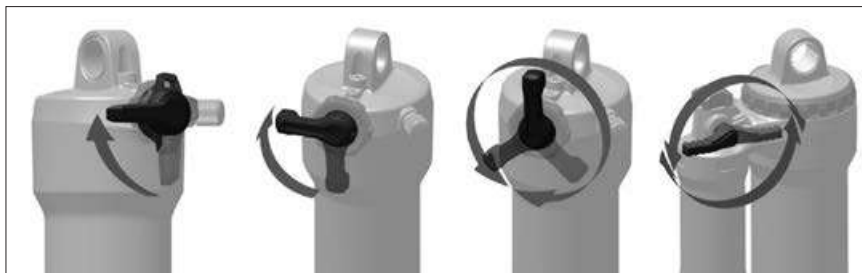

Adjusting the lockout

The *lockout* setting prevents the shock from compressing until significant impact or downward force occurs. The shock will compress when the force exceeds the damper blow-off circuit resistance. Use the *lockout* setting for maximum pedalling efficiency on smooth or rolling terrain. Rotate the lever, or actuate the remote, to lock and unlock the compression damper.

You can find more info about rear suspensions on www.sram.com/rockshox.

Front suspension

Rebound damping controls the suspension fork extension/return speed, which affects traction and control. Optimal rebound damping allows the fork to extend at a controlled speed and maintain traction and control. Rebound that is too fast allows the fork to extend too quickly, which causes the wheel to bounce off objects and the ground resulting in a *pogo* effect. Rebound that is too slow prevents the fork from extending quickly enough to regain contact with the ground or prepare for the next impact. Rebound damping can be tuned to rider weight, spring rate and travel, as well as for terrain and rider preference.

As the air pressure or spring rate increases, the extension/return speed increases. To achieve the optimal setting, rebound damping may need to be increased when air pressure or spring rate increases.

For recommended rebound settings, go www.sram.com/rockshox.

After setting the sag, adjust the rebound damper, go for a ride, and adjust again as preferred.

Shock pressure chart

Check values on front fork. If values on front fork and in this manual are different use values given on front fork.

FRONT FORK – AIR SPRING PRESSURE

G6.1 & G6.1(US)							
ROCK SHOX YARI RC 27.5" BOOST DEBONAIR, 150MM [5.9"] TRAVEL, 15MM [0.6"] AXLE							
<55 kg	55–63 kg	63–72 kg	72–81 kg	81–90 kg	90–99 kg	>99 kg	MAX PSI
<65 psi	65–75 psi	75–85 psi	85–95 psi	95–105 psi	105–115 psi	115+ psi	163

G6.2, G6.20 & G6.2(US)
ROCK SHOX LYRIK SELECT+ 27.5" BOOST DEBONAIR, 150MM [5.9"] TRAVEL, 15MM [0.6"] AXLE

<55 kg	55–63 kg	63–72 kg	72–81 kg	81–90 kg	90–99 kg	>99 kg	MAX PSI
<65 psi	65–75 psi	75–85 psi	85–95 psi	95–105 psi	105–115 psi	115+ psi	163

FRONT FORK – AIR SPRING PRESSURE

G6.3 & G6.3(US)
ROCK SHOX LYRIK SELECT+ 27.5" BOOST DEBONAIR, 150MM [5.9"] TRAVEL, 15MM [0.6"] AXLE

<55 kg	55–63 kg	63–72 kg	72–81 kg	81–90 kg	90–99 kg	>99 kg	MAX PSI
<65 psi	65–75 psi	75–85 psi	85–95 psi	95–105 psi	105–115 psi	115+ psi	163

Recommended tire pressure

The tire pressure is an important factor for riding your bike properly. If the tire pressure is too high, the tire will not conform to the ground, reducing traction. It is important to have an accurate pressure gauge when setting the tire pressure; preferably a digital gauge with a 0.03 [bar] (0.5 [psi]) accuracy.

The recommended tire pressure will vary slightly based on rider weight, riding style, and terrain. Some riders may find it helpful to start a ride at a slightly higher pressure than recommended and let out a little air throughout the course of the ride until you find your ideal riding tire pressure.

The maximum inflation pressure is 2.6bar (38psi)



WARNING — If the maximum pressure values in this manual and values on the side wall of a tire are in any way different, please refer to the ones that are marked on the tire's sidewall or wheel (which ever is lowest). Never inflate a tire beyond the maximum pressure marked on the tire's sidewall. Exceeding the recommended maximum pressure may blow the tire off the rim, which could cause damage to the bike and injury to the rider and/or bystanders.

You can find the minimum recommended tire pressure on the tire side wall. Never inflate tire below the minimum recommended tire pressure. If the tire pressure is too low, the tire could pinch flat and be difficult to handle and can cause loss of control.

Assembling parts supplied unassembled



CAUTION – Do not use the chainguide and chainguard at the same time.

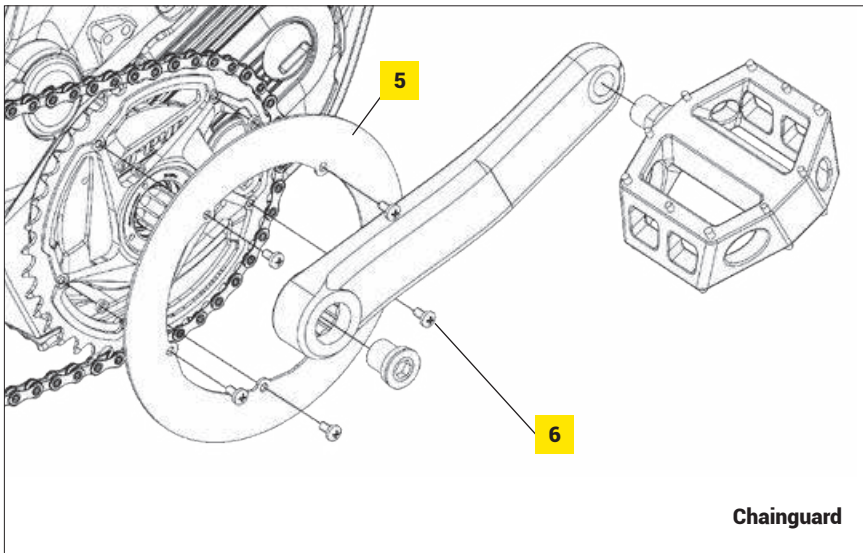
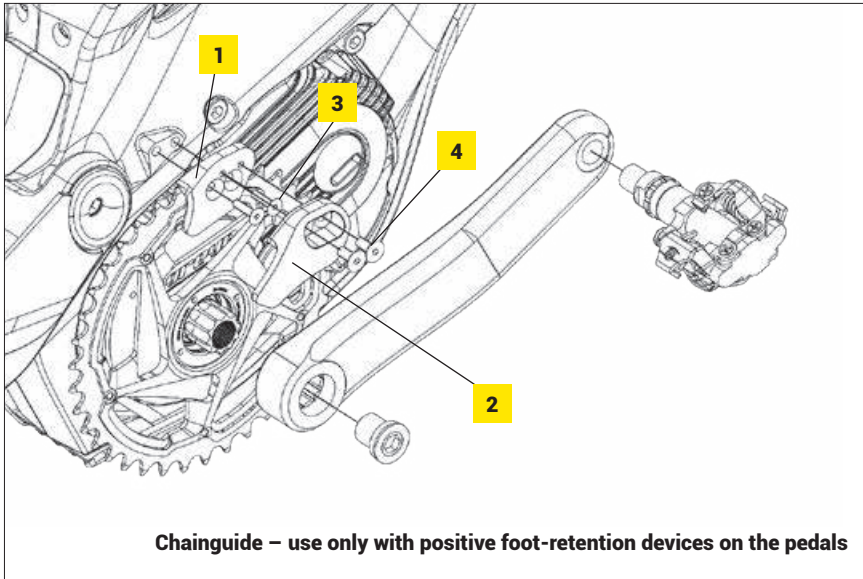

CHAINGUIDE OR CHAINGUARD MOUNT

	NAME/DESCRIPTION	TORQUE, Nm [lbf ft]
1	CHAINGUIDE ALUMINUM PART	-
2	CHAINGUIDE PLASTIC PART	-
3	DIN 7991 M5X18	4 [3]
4	DIN 7991 M5X12	4 [3]
5	CHAINGUARD	-
6	ISO 7045 M4X8	4 [3]

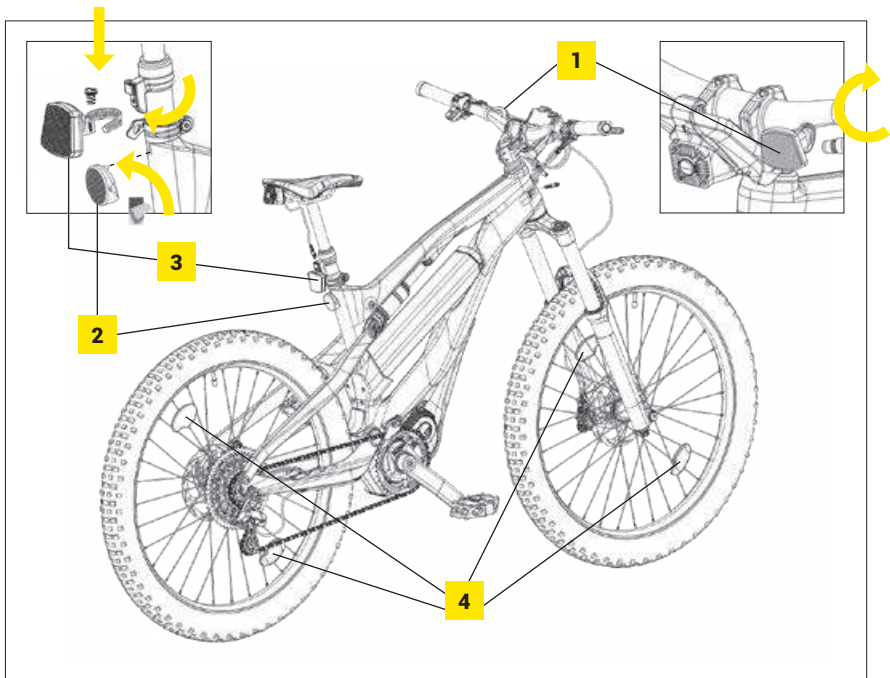

REFLECTORS

	NAME/DESCRIPTION
1	FRONT REFLECTOR 313/5K
2	REAR REFLECTOR 314/1
3	REAR REFLECTOR 313/1ZB
4	SPOKE REFLECTOR 309 (M); (US - RR-530-WUW)

3

Battery and charger

Your bike is powered by a Lithium-ion (Li-ion) battery. Always adhere to the following instructions when handling or charging the battery or when using your Greyp bike. Only use the Greyp battery with the corresponding Greyp bike. Do not use the Greyp battery with other products or any other battery with the Greyp bike, even if it fits.

Turn off the bike, unplug the charger from the bike and remove the battery from the bike before performing work of any kind, such as installation, maintenance, cleaning and/or repair. When transporting or handling the battery separately from your Greyp bike, ensure the battery is turned OFF (you can do this by plugging the battery to the bike and if the bike doesn't turn on by itself that means that the battery is turned OFF). Touching the contacts when the battery is ON can result in electric shock and/or injury.

Before riding your bike, make sure the battery is properly secured in the frame.

Do not modify, open or disassemble the battery or charger, as modification or disassembly may result in a short circuit, fire or malfunction.

Be careful when handling the battery and do not drop it.

Battery technical data

GREYP G6 BATTERY PACK INFORMATION

MANUFACTURER:	GREYP BIKES D.O.O.
MODEL/TYPE REFERENCE:	6G-01
WEIGHT:	3.5 Kg
BATTERY TYPE DESIGNATION:	10INR19/66-6
CELL CONFIGURATION:	10S6P
CAPACITY (AH):	19.3 Ah
ENERGY (WH):	700 Wh

GREYP G6 BATTERY PACK INFORMATION

COMMUNICATION:	CAN
APPLICATION USING ENVIRONMENT:	INDOOR AND OUTDOOR, -20~50 °C [-4~122°F]
COOLING:	NATURAL CONVECTION
CHARGING	BETWEEN 0-40°C [32~104°F]
PROTECTION:	PROTECTION TYPE: FUSE/ CELL CHRГ TEMP, DISCHRG TEMP / CELL VOLTAGE PROTECTION RATING : 40 A/ 0°C [32°F] TO 55°C [131°F] , -20°C [-4°F] TO 60°C [140°F] / 2.5 TO 4.19 VOLTS OVERLOAD PROTECTION: 30 A, 5 s SHORT CIRCUIT PROTECTION: 150 A
OTHER INFORMATION:	CELL INFORMATION : LG INR18650-MJ1, Li-Ion, 3.63V, 3500mAh OUTPUT CONNECTOR: RoPD TYPE, AUTOMOTIVE, 48V, 30A, UV RESISTANT
CHARGING METHOD:	CC/CV
I CHARGE MAX:	9.0 A
I CHARGE:	4.0 A (OPTIONAL: 8.0 A)
I DISCHARGE:	20.0 A CONTINUOUS
U CHARGE MAX:	42.0 V
U CHARGE NOM:	36.3 V
U DISCHARGE END:	25.0 V
U CHARGE END:	41.9 V
CERTIFICATION:	UN 38.3 (6TH ED.)

Important battery information



WARNING — Failure to follow the instructions in this section may result in damage to electrical components on your bike and will void your warranty, but most importantly, may result in serious personal injury or death. If your battery or charger exhibits any signs of damage, do not use it and immediately bring it to your authorized Greyp Bikes retailer for inspection.



The connector used for the battery and charger is magnetised (RoPD) and can attract metal objects. Do not allow any screws or other small, sharp and/or metallic objects to come in contact with the battery connector, bike charging socket or charger connector.

Every time before you plug in the battery or charger, check the battery connector, bike charging socket and charger connector for any damage or foreign objects. In case of any damage do not connect the battery or battery charger and please contact your authorized Greyp retailer. In case of a foreign object please remove it before you connect the battery to your Greyp bike.

Keep the battery away from metal objects as they can cause a short-circuit.

Do not allow the battery to overheat. Protect the battery from excessive sun exposure. Do not expose the battery to an open fire or radiator heat.

Do not immerse the battery in water. Do not directly spray the battery (or the connectors if the battery is removed) with pressured water.

In the event of an inadequate connection between the charger connectors and the battery connector or charging socket there could be functional problems and it is a potentially hazardous situation. In this case you should disconnect the charger connector and the battery and check what caused the inadequate connection.

Do not use a battery that shows any signs of damage (hollow casing, cracked lid, cracked connector, damaged connector) or is leaking any fluids. Battery liquid can cause skin irritation and burns. In the event of damage that results in skin or eye contact with any liquid from the battery, immediately flush with water and seek medical assistance.

The battery is heavy. Be careful when handling it and do not drop it.

Do not connect the battery connector, bike charging socket or the charger connector if it is wet. You can use a dry cloth to dry the battery connector, bike charging socket or charger connector. It is important that you follow the instructions on the label of the battery charger and always use an appropriate Greyp charger.

The battery can be charged whether it is installed in the bike or not. Refer to the appropriate instructions regarding removing and installing the battery. Only charge the battery at an ambient temperature between 0°C and 40°C (32°F and 104°F). If the outside temperatures are too hot or too cold, charge the battery inside. For safety reasons, if the battery is too hot or too cold, it will not charge.



ON BATTERY

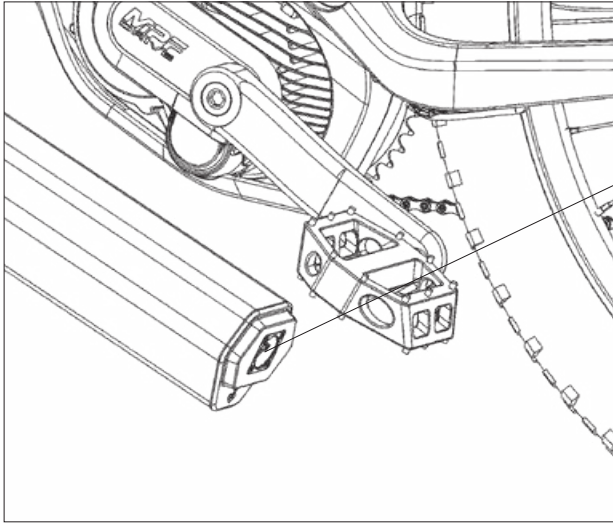

Charging socket

ON BIKE

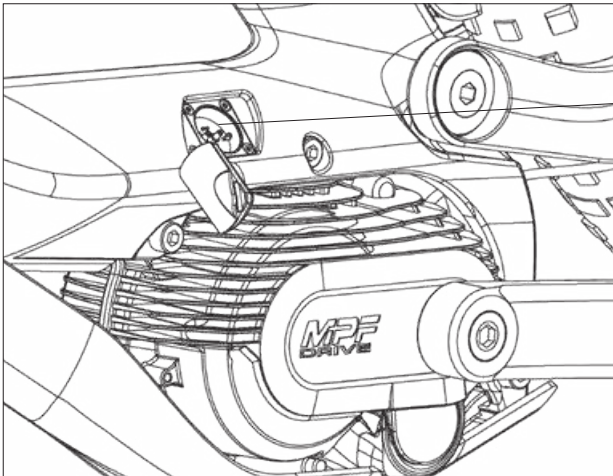

Charging socket

Plug the charger plug into an appropriate AC outlet (depending on the charger) using the appropriate plug/adaptor for the country's standard.

Uncover the charging socket on the bike, then connect the charger to the charging socket on the bike. It is possible to charge the battery when removed from the bike. In that case, plug the charger into the battery socket.

During the charging process, the light on the charger will glow red. When the battery is fully charged, the light on the charger will turn green. When monitoring the charging process, please check the LED light on the charger.

When charging is complete, disconnect the charging plug from the battery socket. Unplug the charger from the wall socket.

Make sure that the input voltage of the charger is in range of the power grid voltage you plan to use.



CAUTION: If the red LED light is flashing during the charging process, a charging error has occurred. In that case, immediately remove the charger from the socket, discontinue the use of the motor support and contact an authorized Greyp retailer.



CHARGER 1

Model: BC222360040

Input: 100-240 V AC, 2.5 A (max), 50/60 Hz

Output (max): 42 V DC, 4 A

LED indicator



CHARGER2 (EU ONLY)

Model: STC-8150LC

Input: 220-240 V AC, 50/60 Hz, 180 W

Output (nom): 36 V DC, 4 A

LED indicator

Battery life

The bike should be stored in dry conditions. If you plan to store the battery for a period longer than few weeks, please make sure that the SoC (State of Charge) is between 30% and 40%. It is necessary to check the battery frequently, even if the bike is not being used, in order to avoid permanent damage to the battery.

Strongly reduced operating time after charging can be a sign that the battery is reaching the end of its useful life and must be replaced. Provided your Greyp bike has been used properly, approximately 80% of the battery's original capacity should remain after 500 charging cycles or two years.

Recharging the Greyp G6 battery takes approximately 5 hours. It is recommended that you don't wait for the battery to completely empty before recharging. Do not leave a full or empty battery for a longer period of time, as this will reduce the battery life. Try to keep the battery between 20%-80% to extend the battery life. If you know that your planned route is shorter and you don't need a full battery, we recommend that you charge the battery up to 80% of SoC instead of 100%. This way you will keep a better battery life.

The worst thing you can do is to leave a complete empty battery uncharged for a longer period of time. This could lead to a reduced battery life or permanent damage to the battery pack.

4

System functions

Bike parts

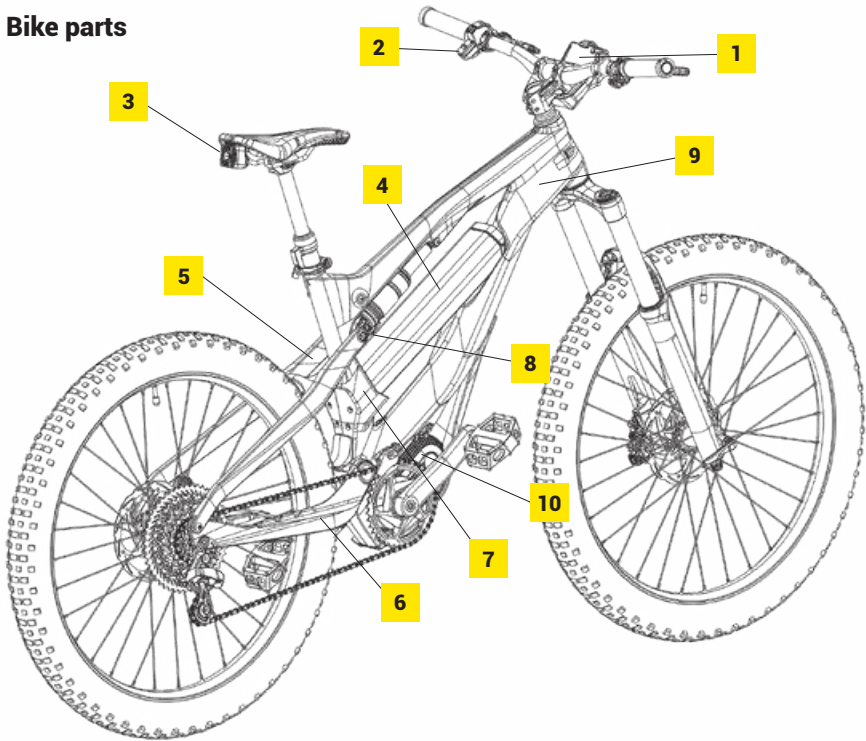

BIKE PARTS

NAME/DESCRIPTION

1	DISPLAY UNIT (CIM)	6	CHAINSTAY
2	CONTROL UNIT (CBC)	7	PUSHPLATE
3	REAR CAMERA (BUTS)	8	RATIO LEVER
4	BATTERY	9	FRAME
5	SEATSTAY	10	MOTOR

Control unit functions

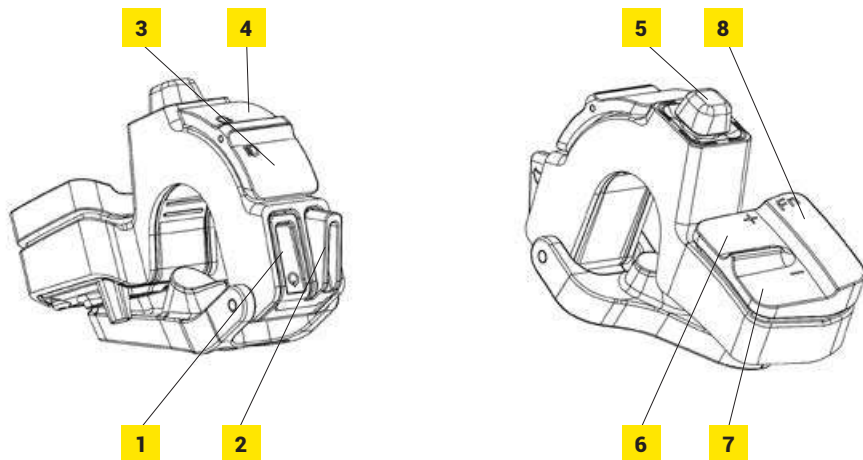

LEGEND

NAME/DESCRIPTION	ICON	FUNCTION	TYPE
1 POWER		ON/OFF AND STAND BY	LONG/SHORT PRESS
2 WALK ASSIST		WALK ASSIST	PRESS & HOLD
3 LIGHT		TURN ON/OFF FRONT AND REAR SIGNAL LIGHTS	SHORT PRESS
4 RETRO VIDEO		WORKS ONLY WITH MOBILE APP	
5 JOYSTICK		SWITCH BETWEEN DISPLAY FUNCTIONS	SHORT PRESS IN ALL DIRECTIONS
6 ASSIST LEVEL UP		INCREASE LEVEL OF ASSISTANCE	SHORT PRESS
7 ASSIST LEVEL DOWN		DECREASE LEVEL OF ASSISTANCE	SHORT PRESS
8 FUNCTION		VARIOUS FUNCTIONALITIES (SEE NEXT PAGES)	

Display unit information

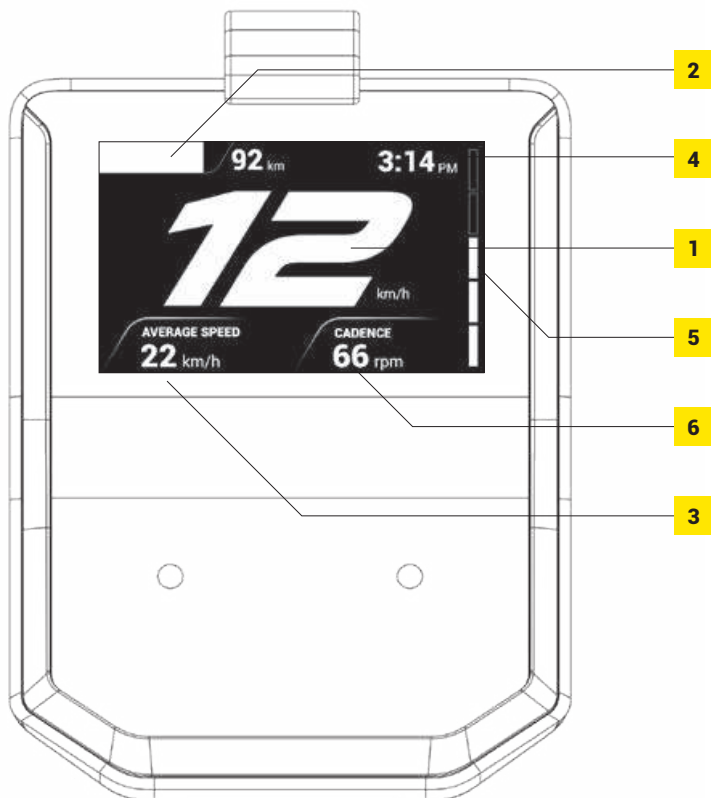

CIM DISPLAY INTERFACE

NAME/DESCRIPTION	
1	SPEED
2	BATTERY CHARGE / REMAINING DISTANCE
3	RIDE STATISTICS
4	TIME
5	ASSISTANCE LEVEL
6	CADENCE

Power on



To turn on the bike, long press the power button

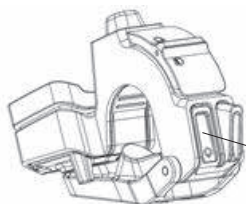

Long press

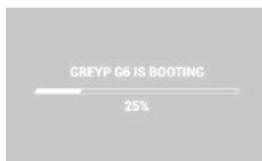

Stand by mode on



To put your bike in standby mode, short press the power button

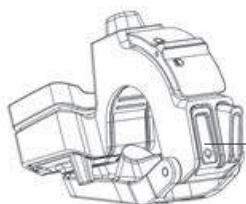

Short press



Stand by mode off

To wake up the bike from stand-by mode, press any button on the control unit or move the bike

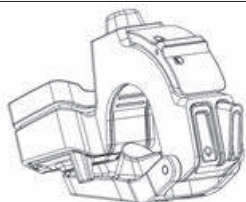

Press any button



Power off

 To turn off the bike, long press the power button

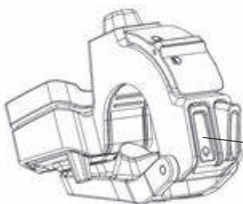

Long press

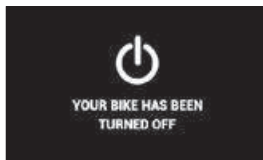

Walk assist mode

 To activate the walk assistance mode, press and hold walk assist button

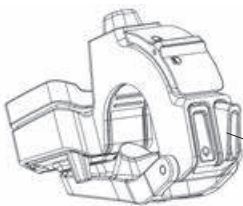

Press and hold

Lights on/off

 To turn the lights on or off, short press the light button

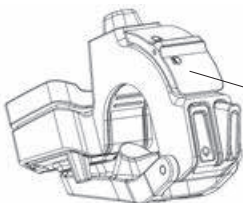

Short press

Joystick

 To switch between different information on the display unit, move the joystick up or down

- » TRIP
- » ODOMETER
- » AVERAGE SPEED
- » TRIP TIME

Move in the up or down direction



Assist level up/down

 To change the assistance level, short press the plus or minus assist level button

Short press to change by one level

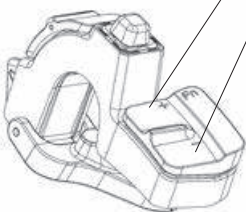

Info and Pair a bike screen

Fn +  To access the Info screen, use a combination of buttons.

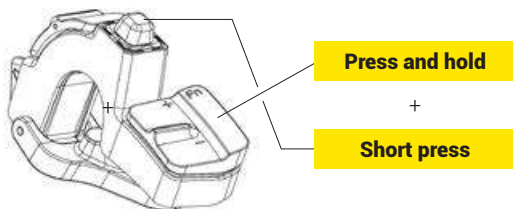

 Move the joystick up or down to scroll inside the screen or move the joystick left/right to switch between screens

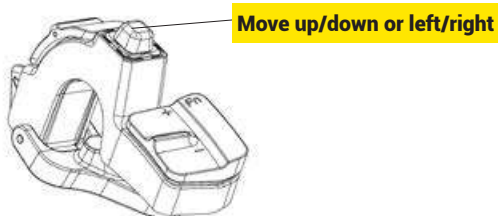

Manual Software Update

Fn +  To start the software update use a combination of buttons. Make sure your bike is connected to a charger and that it is connected to your personal hot spot.

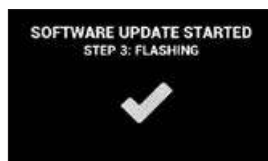
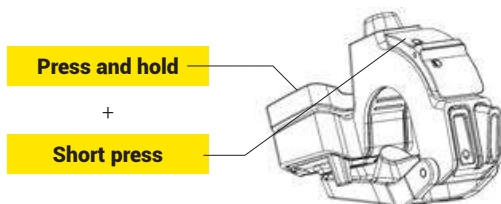

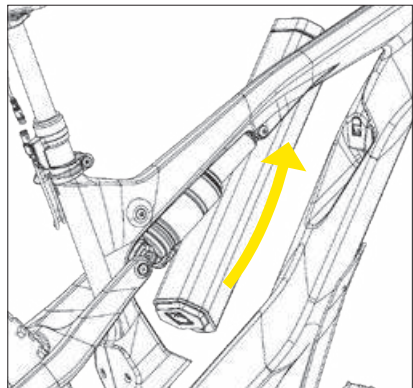
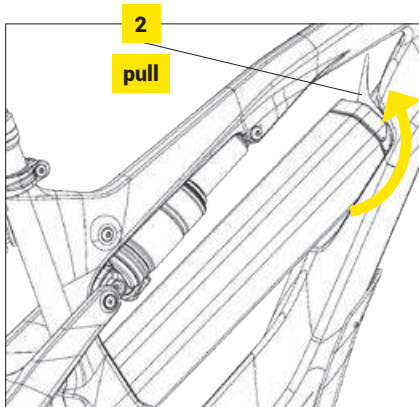
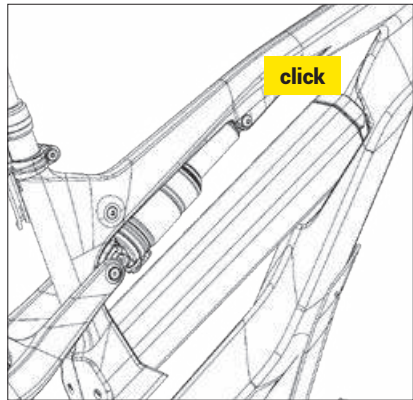
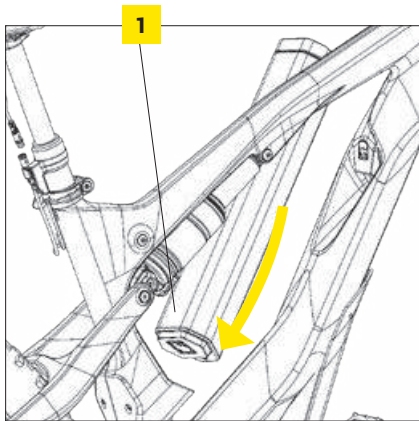

BATTERY PACK MOUNT/DISMOUNT

NAME/DESCRIPTION

1 BATTERY

2 BATTERY LOCK

5

Bike maintenance & range

Maintenance



WARNING – Failure to follow the instructions in this section may result in damage, serious personal injury or death. If your bike exhibits any signs of damage, do not use it and immediately bring it to your authorized Greyp Bikes retailer for inspection.

All regular maintenance, troubleshooting, repair and parts replacement must be performed by an authorized Greyp retailer.



WARNING – If your use of a bicycle applies more stress than that which is intended, the bicycle or its parts can be damaged or broken. A bicycle that has damage could decrease your control and cause you to fall. Do not ride in conditions that apply more stress than the limits of the bicycle. If you are not sure of the limits of the bicycle, consult your bike shop.

Great care should be taken to not damage carbon fibre or composite material. Any damage may result in a loss of structural integrity, which may result in a catastrophic failure. This damage may or may not be visible on inspection. Before each ride, and after any crash, you should carefully inspect your vehicle for any fraying, gouging, scratches through the paint, chipping, bending, or any other signs of damage. If discovered, do not ride any further and take your Greyp bike to an authorized Greyp retailer for a complete inspection.

The lifespan and type and frequency of maintenance depend on many factors, such as frequency and type of use, rider weight, riding conditions and/or impacts. Additionally, the Greyp G6 uses a power-assisted drive system, which means more distance at different rates, depending on the component. The drivetrain and brake components are especially subject to wear. Have your authorized greyp retailer inspect your vehicle and components periodically.

Exposure to harsh elements, especially salty air (such as riding near the ocean or in the winter) can result in galvanic corrosion of components, which can accelerate wear and shorten the lifespan of your bike. Dirt can also accelerate the wear of surfaces and bearings. The surfaces of the bike should be cleaned before each ride. Proper care and regular maintenance can help increase the longevity of components. If you notice any signs of corrosion or cracking on the frame or any component, the affected item must be replaced. While riding, listen for any creaks, as a creak can be a sign of a problem with one or more components. Periodically examine all surfaces in bright sunlight to check for any small hairline cracks and if you discover any, no matter how small, or any damage to components, immediately stop riding and have the part inspected by your retailer. The vehicle should also be maintained regularly

by an authorized Greyp retailer, which means it should be cleaned and lubricated. Regularly clean and lubricate the drivetrain according to the drivetrain manufacturer's instructions.

Do not apply lubricant on the disc brake rotors. Lubricant on brake surfaces can cause decreased braking function, and increase the possibility of an accident or injury. If any lubricant or any other fluid gets on the brake disc rotor, remove the wheel from the bike and clean the brake disc rotor thoroughly. If you get any on the brake pads, replace them.

Do not use a high-pressure water spray directly on the bearings. Even water from a garden hose can penetrate the bearing seals and crank interfaces, which can result in increased bearing and crank wear, in turn affecting the normal function of the bearings. Use a clean, damp cloth and bicycle cleaning agents for cleaning. Do not expose the vehicle to prolonged direct sunlight or excessive heat, such as inside a car parked in the sun or near a heat source such as a radiator.

It is very important that you use only original replacement parts for safety-critical components.

Bicycle wheel rims are subject to wear. Ask your dealer about wheel rim wear. Riding a wheel that is at the end of its usable life can result in wheel failure, which can cause you to lose control and fall.

Loose or damaged handlebar grips, end plugs or extensions should be replaced, as they can expose the ends of the handlebar, which have been known to cause injury, and they can cause you to lose control and fall.



WARNING – Riding with an improperly secured wheel can allow the wheel to wobble or fall off the bicycle, which can cause serious injury or death. Therefore, it is essential that you:

1. Ask your dealer to help you make sure you know how to install and remove your wheels safely.
2. Understand and apply the correct technique for clamping your wheel in place.
3. Each time, before you ride the bike, check that the wheel is securely clamped.
4. The clamping action of a correctly secured wheel must emboss the surfaces of the dropouts.

The following parts must only be replaced with original components:

- | | |
|--------------------------|-----------------------|
| » <i>Frame</i> | » <i>Brakes</i> |
| » <i>Battery</i> | » <i>Charger</i> |
| » <i>Display unit</i> | » <i>Motor unit</i> |
| » <i>Electric wiring</i> | » <i>Control unit</i> |
| » <i>Brake hoses</i> | » <i>Sensors</i> |

Appropriate spares:

	TYRES	BRAKES	ROTORS	INNER TUBE
G6.1	SCHWALBE NOBBY NIC PERFORMANCE LINE, 70-584	FORMULA CURA	FORMULA SIX BOLT 203mm [8"] FRONT 180mm [7"] REAR	PRESTA 27.5 PLUS X 2.8/3.0 TUBE
G6.2	SCHWALBE MAGIC MARY EVOLUTION LINE, 70-584	FORMULA CURA 4	FORMULA SIX BOLT 203mm [8"] FRONT 203mm [8"] REAR	
G6.3	SCHWALBE NOBBY NIC PERFORMANCE LINE, 70-584	FORMULA CURA 4	FORMULA SIX BOLT 203mm [8"] FRONT 203mm [8"] REAR	

Parts replacement – recommended values

CHAIN WITH CHAIN RINGS	1,000 KM [621 mi] OR SOONER IF NEEDED
TIRES	EVERY 3 YEARS OR AT WEAR MARK
INNER TUBES	EVERY 3 YEARS OR WHEN NEEDED
FRONT AND REAR HUB BEARINGS	EVERY 2,000 km [1242 mi]
BRAKE PADS	EVERY YEAR OR AT WEAR MARK
BRAKE DISC ROTOR	EVERY YEAR OR AT WEAR MARK
BRAKE FLUID	AS SPECIFIED BY PRODUCER
FORK	AS SPECIFIED BY FORK PRODUCER (see chapter Front suspension)
SHOCK	AS SPECIFIED BY SHOCK PRODUCER (see chapter Rear Suspension)

Range

The range on one charge greatly depends on several circumstances, such as (but not only):

- » *Weather conditions such as ambient temperature and wind;*
- » *Road conditions such as elevation and road surface;*
- » *Bike conditions such as tire pressure and maintenance level;*
- » *Bike usage such as acceleration and shifting;*
- » *Rider and luggage weight;*
- » *Charge and discharge cycles.*

Shifting recommendations

For better range, Greyp advises to shifting according to the speed. For low speeds, low gearing is best. The higher the speed, the higher the gear that can be chosen. For a smooth support and optimum range, it is best to release the pedal pressure while shifting gears.

- » *high speed, high gear*
- » *low speed, low gear*
- » *release power during shifting*

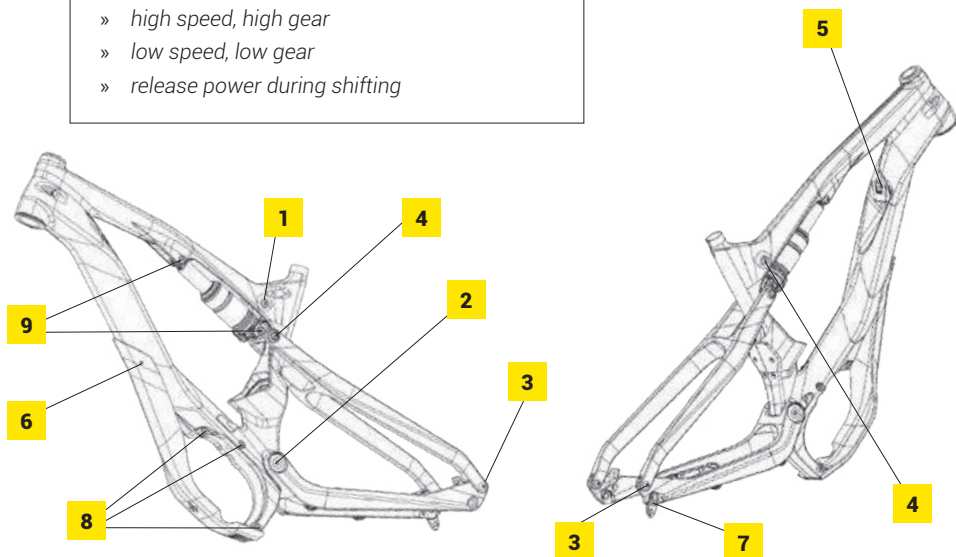

Recommended tightening of fasteners

FRAME TORQUE SPECIFICATION

	NAME / DESCRIPTION	TORQUE, Nm [lbf ft]
1	RATIO LEVER / FRAME	8 [5.9]
2	FRAME / CHAINSTAY	20 [14.8]
3	CHAINSTAY / SEATSTAY	8 [5.9]
4	SEATSTAY / RATIO LEVER	10 [7.4]
5	BATTERY LOCK	2-3 [1.5-2.2]
6	SKID PLATE	5 [3.7]
7	DROPOUT	6 [4.4]
8	FRAME / MOTOR	10 [7.4]
9	RATIO LEVER / REAR SHOCK / FRAME	8 [5.9]

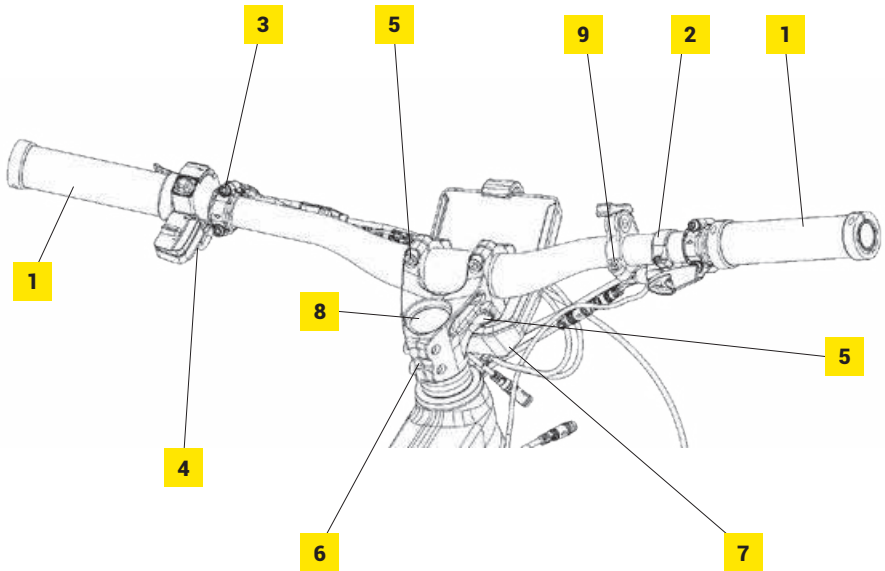

HANDLEBAR PARTS / STEM / TORQUE SPECIFICATION

	NAME / DESCRIPTION	TORQUE, Nm [lbf ft]
1	GRIPS / HANDLEBAR	G6.1 & G6.2 - 2[1.5], G6.3 - 3 [2.2]
2	SHIFTER / HANDLEBAR	4 [3]
3	BRAKE LEVERS / HANDLEBAR	4 [3]
4	CBC / HANDLEBAR	1,2 [0.9]
5	STEM / HANDLEBAR	9 [6.6]
6	STEM / FRONT FORK	12 [8.9]
7	CIM / STEM	1 [0.7], MAX <2 [1.5]
8	HEADSET / FRONTFORK	6 [4.4]
9	SEATPOST / HANDLEBAR	3 [2.2]

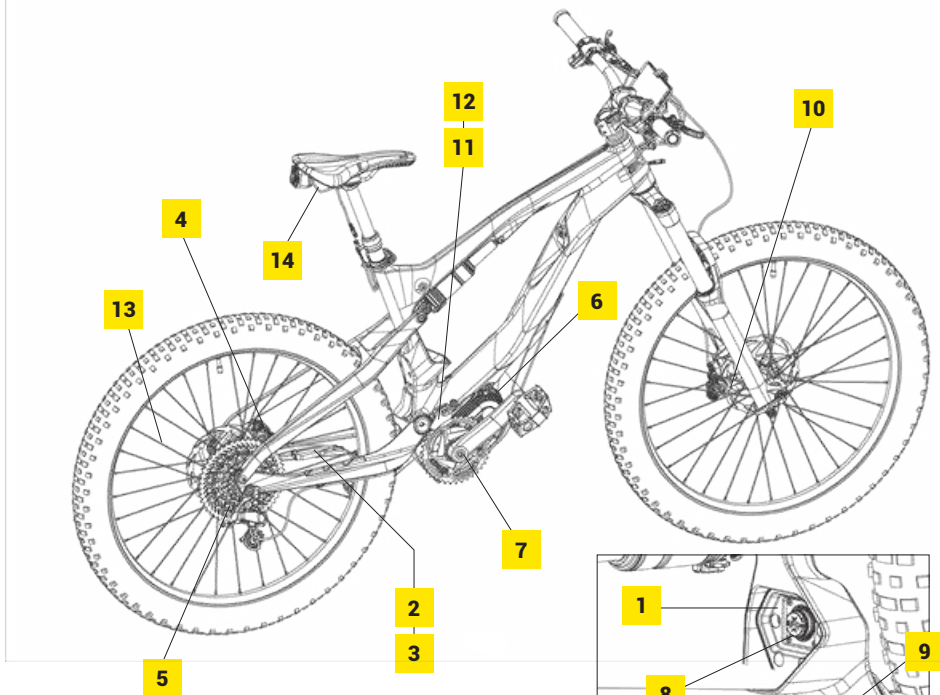

BIKE COMPONENTS TORQUE SPECIFICATION

	NAME / DESCRIPTION	TORQUE, Nm [lbf ft]
1	PUSHPLATE / FRAME	4 [3]
2	SPEED SENSOR / CHAINSTAY	2 [1.5]
3	SPEED SENSOR / SPEED SENSOR HOLDER	2 [1.5]
4	REAR BRAKE / CHAINSTAY	6 [4.4]
5	DERAILLEUR / DROPOUT	12 [8.9]
6	CHAINWHEEL / MOTOR	30 [22.1]
7	CRANKARMS / MOTOR	40 [29.5]
8	Y WIRING / PUSHPLATE	1 [0.7]
9	Y WIRING / FRAME	1 [0.7]
10	FRONT BRAKE / FRONT FORK	6 [4.4]
11	CHAINGUIDE ALU PART / FRAME	4 [3]
12	CHAINGUIDE PLASTIC PART / ALU PART	4 [3]
13	SPEED SENSOR MAGNET / WHEEL SPOKES	< 2 [1.5] MAX
14	SEAT POST / SEAT	10 [7.4]

6

Cleaning the bike

Most cleaning can be done with soap, water, sponges and brushes.

- » *Avoid using high-pressure sprayers because water can penetrate through seals ;*
- » *Avoid using corrosive soaps and strong solvents – always use cleaning products intended for an electric bicycle ;*
- » *For an extremely dirty chain we recommend use of a solvent-bath chain cleaner.*

Chain

After every wash, the chain should be wiped and lubricated. After every few rides, lube slightly. After every 400 km [250 mi], check for chain elongation. Use a chain-elongation gauge to determine whether the chain should be replaced.

Fork

Wipe and clean the forks after every ride. After 50 hours of riding perform lower leg service. After 200 hours of riding perform damper and spring service.

Performing the right maintenance on your RockShox products not only ensures years of worry-free riding, but will also keep performance optimal and enhance your experience on the bike. Each service interval indicates the maximum number of riding hours designated for each type of recommended maintenance. Depending on the terrain and environmental conditions in your location, your riding style and skill level, you may see more optimum performance if you service your RockShox products at shorter intervals. For specific detail check the suspension manufacturer service manuals.

Shock

Wipe and clean the shock after every ride. After 50 hours of riding perform air can service. After 100 hours of riding perform damper and air can service.

Performing the right maintenance on your RockShox products not only ensures years of worry-free riding, but will also keep performance optimal and enhance your experience on the bike. Each service interval indicates the maximum number of riding hours designated for each type of recommended maintenance. Depending on the terrain and environmental conditions in your location, your riding style and skill level, you may see more optimum performance if you service your RockShox products at shorter intervals. For specific details, check the suspension manufacturer service manuals.

Have all repairs performed only by an authorised bike dealer.

Lubrication

Consult with your retailer to choose among the many types of chain lubes best suited to your climate and riding conditions. Every month, lubricate all of the pivot points of the rear derailleur, as well as on the jockey wheels.

7

Warranty

General

Greyp products have been manufactured and tested to the highest quality standards by Greyp Bikes d.o.o. This limited warranty offered by Greyp Bikes d.o.o. covers defects in material or workmanship in new Greyp products. Greyp warrants this product against defects in material or workmanship for a period of 24 months after the first purchase. Greyp will replace any product or part of the product that proves defective due to improper workmanship and/or material, under normal installation, use, service and maintenance. If Greyp is unable to provide a replacement and if a repair is not practical or cannot be made in a timely fashion, Greyp may elect to refund the purchase price in exchange for the return of the product.

This warranty extends to the original purchaser only and is non-transferable. This warranty does not apply to rental or commercial use bicycles. Only consumers purchasing Greyp products from authorized Greyp retailers or resellers or through the Greyp website may obtain coverage under our limited warranties. This warranty does not cover any damage or defects resulting from a failure to follow instructions in the user manual, alterations to the original design, acts of God, accident, misuse, neglect, abuse, improper assembly, operator error, water damage or improper follow-up maintenance. Greyp explicitly exempts from coverage any damage to bicycles used for jumping, stunt riding, rental programs, observed trials and any similar extreme riding or events.

Incidental and consequential damages are also not covered. Greyp does not cover the cost of international warranty shipping at any time, for any reason. This warranty is expressly limited to the replacement of defective parts with those of equal or greater value at the sole discretion of Greyp Bikes d.o.o.

The repair, replacement or refund of the purchase price, as provided by this warranty, is the exclusive remedy of the purchaser. Greyp Bikes neither assumes nor authorizes any person to create for it any other obligation or liability in connection with this warranty. Greyp Bikes shall not be liable to the purchaser or any other person for any incidental, special or consequential damages, arising under this warranty or any implied warranty, including without limitation, damages for personal injury, property damage or economic losses, whether based on the contract, warranty, negligence or product liability in connection with their products.

Some components of Greyp bikes are subject to wear and tear due to their function. The rate of wear will depend on care and maintenance and the way the bike is used. Bikes that are often left in the open may also be subject to increased wear through weathering. The

components below require regular maintenance. Nevertheless, sooner or later they will reach the end of their service life, depending on the conditions and intensity of use. The following parts that have reached their limit of wear and tear must be replaced :

- | | |
|----------------------------------|------------------------------|
| » <i>Battery</i> | » <i>Brake hoses</i> |
| » <i>Chainrings and cassette</i> | » <i>Lubricants</i> |
| » <i>Drive chain</i> | » <i>Dropper post seals</i> |
| » <i>Hubs and free hubs</i> | » <i>Suspension elements</i> |
| » <i>Brake pads</i> | » <i>Wheels and spokes</i> |
| » <i>Inner tubes and tires</i> | » <i>Grips</i> |
| » <i>Brake fluid</i> | » <i>Cables/connectors</i> |
| » <i>Brake disc rotors</i> | » <i>Pedals</i> |
| » <i>Bearings</i> | |

Battery

If the battery fails completely during the first 24 months or 500 cycles (whichever comes first) from the original date of purchase, it will be replaced or repaired at no charge. Lithium batteries require care and some maintenance to maximize life expectancy (please read chapter Battery life). Abusing the battery will void your warranty.

The warranty is void in the following cases:

- | |
|--|
| » <i>if damage is caused by power surge</i> |
| » <i>if damage is caused by the use of an improper charger</i> |
| » <i>if damage is caused by improper maintenance or other such misuse</i> |
| » <i>if damage is caused by normal wear</i> |
| » <i>if damage is caused by water damage</i> |
| » <i>if the battery is charged below 0°C [32°F]</i> |
| » <i>if the battery is below 20% of its capacity and not charged in the period longer than one month</i> |

If a battery needs to be removed for return shipment to Greyp, it is the customer's responsibility to safely remove and send the battery to Greyp at their own cost. Greyp will reimburse the customer for its own labour & replacement parts in the first 24 months of bike ownership. Greyp will pay to return the battery to the customer. Greyp retains the right to repair or replace

battery at its sole discretion. All lithium batteries must be shipped as Class 9 dangerous goods (HAZMAT) and must be shipped in accordance with all local and international laws. Lithium batteries sold by Greyp can and should NEVER be taken on board a passenger aircraft.

Frame

The Greyp frame is covered by a warranty against defects for 24 months from the original date of purchase for the original owner. If a frame is found to be defective, EU shipping, parts and labour to replace the frame is paid by Greyp for the first 24 months from the original date of manufacture. The cost of repairing/replacing custom paint is never included in frame warranty at any time.

Motor

The motor is warranted for 24 months from the original date of purchase to be free from defects. In the event of a warranty claim requiring the motor to be returned to Greyp, the customer is responsible for the removal and shipment to Greyp. Greyp pays for the parts, in-house labour and the return shipping.

Electronics

The electronics components are warranted for 24 months from the original date of purchase to be free from defects. In the event of a warranty claim requiring the electronics to be returned to Greyp, the customer is responsible for removal and shipment to Greyp. Greyp pays for parts, in-house labour and the return shipping.

Brakes

The brakes are warranted for 24 months from the original date of purchase to be free from defects. Normal wear of the brake pads and brake disc rotors is not covered. Warranty claims on components are made in accordance with the component manufacturer's guidelines. In the event of a warranty claim requiring the components to be returned to Greyp, the customer is responsible for the removal and shipment to Greyp. Greyp pays for parts, in-house labour and return shipping.

Suspension

The suspension units are warranted for 24 months from the original date of purchase to be free from defects. Normal wear of the suspension, such as oil changes and leaking seals are not covered. Warranty claims for components are made in accordance with the component manufacturer's guidelines. In the event of a warranty claim requiring the components to be returned to Greyp, the customer is responsible for the removal and shipment to Greyp. Greyp pays for parts, in-house labour and the return shipping.

Drivetrain

The drivetrain includes the sprockets, shifting system, chain and wheels. Drivetrain units are warranted for 24 months from the original date of purchase to be free from defects. Normal wear and tear of the drivetrain, such as chain and sprocket wear, tire flats, bent wheels, spokes, hubs, free hubs, bearings and worn tires are not covered. Warranty claims for components are made in accordance with the component manufacturer's guidelines. In the event of a warranty claim requiring the components to be returned to Greyp, the customer is responsible for the removal and shipment to Greyp. Greyp pays for parts, in-house labour and return shipping.

How to file a claim

Greyp Bikes d.o.o. will not provide any warranty coverage unless claims are made in compliance with all the Greyp Bikes d.o.o. Warranty Terms and Conditions and the proper return procedure is not followed. To request a warranty service, the Greyp Customer Service Department needs to be contacted and the following information needs to be clearly provided:

- » *the sales receipt or other evidence of the date and place of purchase*
- » *full name, contact details (including telephone number and email address)*
- » *build number of the bike*
- » *a description of the problem*
- » *images or video evidence of the problem*
- » *delivery of the product or the defective part, postage prepaid and carefully packed and insured, to Greyp Bikes d.o.o. or an agreed dealer*

The product or defective part has to be delivered to Greyp Bikes d.o.o. or an agreed dealer postage prepaid and carefully packed and insured. When the warranty service is completed, any repaired or replacement product or part will be returned to the customer postage prepaid. Greyp Bikes d.o.o. reserves the right to inspect any defective components or products to determine whether a repair or replacement is required.

Greyp Bikes d.o.o., Ljubljanska 7, 10431 Sveta Nedelja, Croatia

8

Disposal

The drive unit, on-board computer the including operating unit, battery pack, speed sensor, accessories and packaging should be disposed of in an environmentally correct manner.

Only for EC countries:

According to the European Guideline 2012/19/EU, electrical devices/tools that are no longer usable, and according to the European Guideline 2006/66/EC, defective or used battery packs / batteries, must be collected separately and disposed of in an environmentally correct manner.

Please return the battery packs and on-board computers that are no longer usable to an authorised bicycle dealer.

Batteries and chargers must not be disposed in your household trash! All batteries and chargers must be disposed in an environmentally friendly manner, in accordance with the battery disposal regulations in your country or state. Ask your authorized Greyp retailer for information on how to dispose a battery or charger and any applicable take-back programs.

9

EC – Declaration of conformity

MANUFACTURER	GREYP BIKES D.O.O.
Address	Ljubljanska 7, 10431 Sveta Nedelja, Croatia
Description of product	Greyp G6.1 – Pedelec (EPAC - electric power assisted cycle) Greyp G6.2 – Pedelec (EPAC - electric power assisted cycle) Greyp G6.3 – Off-road vehicle GREYP G6.20 – OFF-ROAD VEHICLE
Name and address of the person authorised to compile the technical file	Domagoj Topličanec, Ljubljanska 7, 10431 Sveta Nedelja, Croatia
The place and date of the declaration;	29/01/2021, Sveta Nedelja

We hereby expressly declare that the products listed above fulfil all the relevant provisions of the:

Machinery Directive (2006/42/EC), Electromagnetic compatibility (2014/30/EC), Radio Equipment Directive (2014/53/EU), Low Voltage Directive (LVD) (2014/35/ EU), ROHS 2 Directive (2011/65/EU)



The following harmonizing standard was applied to the G6.1 and G6.2:

EN 15194:2017 Bicycles – electrically power assisted cycles – EPAC bicycles.

The following standard was used for G6.1, G6.2, G6.20 and G6.3:

EN ISO 4210, EN ISO 12100:2010
EN 62368-1:2014/AC Feb.:2015/A11:2017/ AC Mar.:2017
EN 62311:2008, EN 301 489-1 V2.1.1 , EN 301 489-17 V3.1.1
EN 301 489-19 V2.1.0 , EN 301 489-52 V1.1.0 ,
EN 300 328 V2.1.1 EN 301 893 V2.1.1 ,
EN 301 511 V12.5, EN 301 908-1 V11.1.1 ,
EN 301 908-2 V11.1.2, EN 301 908-13 V11.1.2,
EN 303 413 V1.1.1

Krešimir Hlede

COO Greyp Bikes d.o.o.

Since we are constantly working on improving our user experience, you can expect frequent mobile app updates

**FIND THE LATEST VERSION OF
THE GREYP APP MANUAL
ON OUR WEBSITE**

WWW.GREYP.COM



The Greyp mobile application is available
on [**Google PlayStore**](#) and [**AppStore**](#)

Greyp Bikes d.o.o.

Ljubljanska 7

10431 Sveta Nedelja

Croatia

Tel: +385 1 409 3377

Fax: +385 1 333 6698

info@greyp.com

GREYP 